

dB-Killer n°80
P/N 3015602801

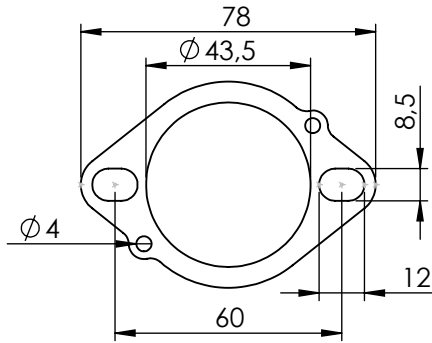

3x S.S. Flanges sp.5mm
P/N 204448

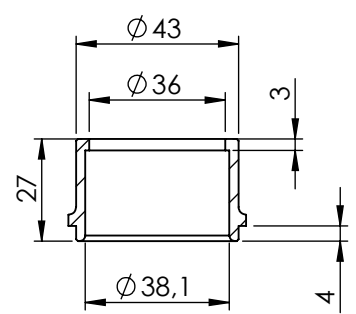

3x S.S. Bushings
P/N 204870

LV 1811 (E49) 92R-02 0003
E49 00029G

S.S. Muffler
P/N 3015602481

Carbon Bracket
P/N 0815611502

S.S. Plate
P/N 207181

S.S. Bracket
P/N 3015619501

Washer
Ø12 Ø6
P/N 200291

Nut M6
P/N 200322

passenger's footpeg

S.S. Primary Pipe Left
P/N 3014371201

S.S. Primary Pipe Centre
P/N 3014371202

S.S. Primary Pipe Right
P/N 3014371203

S.S. Secondary Pipe
P/N 3015619201

3x Flange nuts M8
P/N 200298

Screw
M8x35
P/N 200319

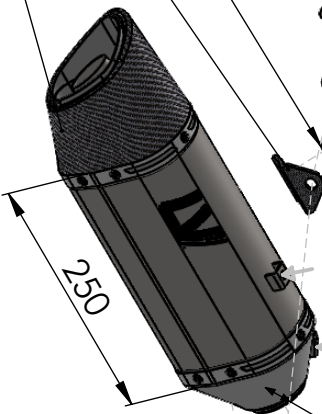

Alu Spacer
Ø22 Ø8,5 h.11
P/N 205090

Screw
M8x20
P/N 200722

S.S. Final Pipe
P/N 3015619203

2x Screws
M5x12
P/N 201031

2x Washers
Ø15 Ø5
P/N 406580

Carbon Heat Shield
P/N 0815607001

4x Gaskets
Ø14 Ø4,9 h.1,5
P/N 200371

2x Mounting plates M5
P/N 204555

Øi.54
Øe.54∇35
Øi.54
Øe.54∇30

bike's frame

Ø54

4x Washers
Ø24 Ø8
P/N 200321

Screw
M8x40
P/N 200993

OPTIONAL
Sonda Lamda / O2 Plug
P/N 5684

M12x1.25

INCLUDED
Sonda Lamda / O2 Plug
P/N 5684

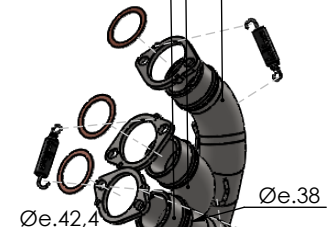

Øe.42,4
Øe.38
Øi.42,4

8x Short Springs
P/N 303949001

LV 1801K e49 00040F

ART. 15619K

YAMAHA MT-09

FULL SYSTEM LV-14R STAINLESS STEEL APPROVED

dB-Killer n°80
P/N 3015602801

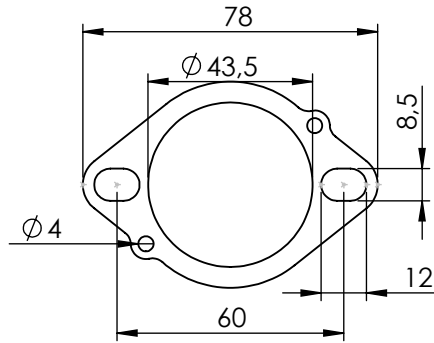

**3x S.S. Flanges sp.5mm
P/N 204448**

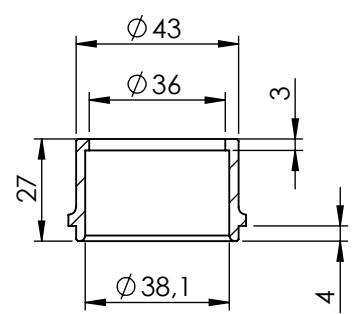

**3x S.S. Bushings
P/N 204870**

LV 1811 (E49) 92R-02 0003
E49 00029G

S.S. Muffler
P/N 3015602481

Carbon Bracket
P/N 0815611502

S.S. Plate
P/N 207181

S.S. Bracket
P/N 3015619502

bike's frame

S.S. Primary Pipe Left
P/N 3014371201

S.S. Primary Pipe Centre
P/N 3014371202

S.S. Primary Pipe Right
P/N 3014371203

S.S. Secondary Pipe
P/N 3015619201

3x Flange nuts M8
P/N 200298

Screw
M8x35
P/N 200319

2x Screws
M6x12
P/N 201265

Alu Spacer
Ø22 Ø8,5 h.11
P/N 205090

Screw
M8x20
P/N 200722

S.S. Final Pipe
P/N 3015619203

2x Screws
M5x12
P/N 201031

2x Washers
Ø15 Ø5
P/N 406580

Carbon Heat Shield
P/N 0815607001

4x Gaskets
Ø14 Ø4,9 h.1,5
P/N 200371

2x Mounting plates M5
P/N 204555

Øi.54
Øe.54∇35
Øe.54∇30

bike's frame

OPTIONAL
Sonda Lamda / O2 Plug
P/N 5684

M12x1.25

4x Washers
Ø24 Ø8
P/N 200321

Screw
M8x40
P/N 200993

Øe.42,4
Øe.38
Øi.42,4

8x Short Springs
P/N 303949001

LV 1801K e49 00040F

INCLUDED
Sonda Lamda / O2 Plug
P/N 5684

ART. 15619K

YAMAHA XSR 900

FULL SYSTEM LV-14R STAINLESS STEEL APPROVED

dB-Killer n°80
P/N 3015602801

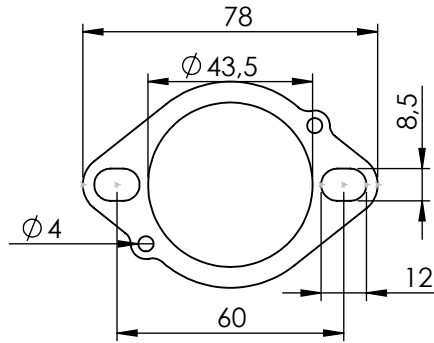

**3x S.S. Flanges sp.5mm
P/N 204448**

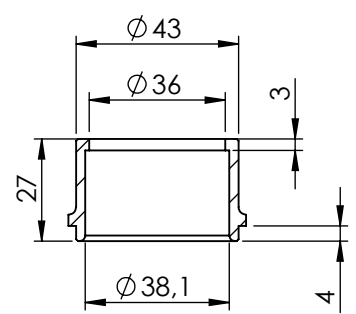

**3x S.S. Bushings
P/N 204870**

LV 1811 (E49) 92R-02 0003
E49 00029G

S.S. Muffler
P/N 3015602481

Carbon Bracket
P/N 0815617501

S.S. Plate
P/N 207181

S.S. Bracket
P/N 3015619503

Nut M6
P/N 200322

Washer
Ø12 Ø6
P/N 200291

passenger's footpeg

S.S. Primary Pipe Left
P/N 3014371201

S.S. Primary Pipe Centre
P/N 3014371202

S.S. Primary Pipe Right
P/N 3014371203

S.S. Secondary Pipe
P/N 3015619201

3x Flange nuts M8
P/N 200298

Screw
M8x35
P/N 200319

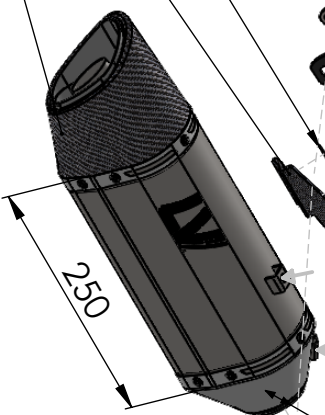

Alu Spacer
Ø22 Ø8,5 h.11
P/N 205090

Screw
M8x20
P/N 200722

S.S. Final Pipe
P/N 3015619203

2x Screws
M5x12
P/N 201031

2x Washers
Ø15 Ø5
P/N 406580

Carbon Heat Shield
P/N 0815607001

4x Gaskets
Ø14 Ø4,9 h.1,5
P/N 200371

2x Mounting plates M5
P/N 204555

Øi.54
Øe.54∇35
Øe.54∇30
Øi.54

bike's frame

OPTIONAL
Sonda Lamda / O2 Plug
P/N 5684

M12x1.25

4x Washers
Ø24 Ø8
P/N 200321

Screw
M8x40
P/N 200993

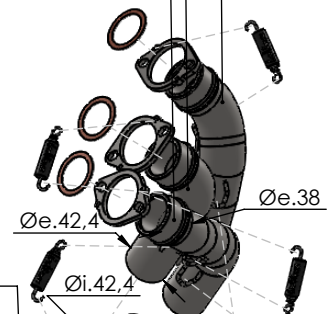

Øe.42,4
Øe.38
Øi.42,4

8x Short Springs
P/N 303949001

LV 1801K e49 00040F

INCLUDED
Sonda Lamda / O2 Plug
P/N 5684

ART. 15619K

YAMAHA R9

FULL SYSTEM LV-14R STAINLESS STEEL APPROVED