



**FITTING INSTRUCTIONS FOR LP0186BK LICENCE PLATE BRACKET**  
**KAWASAKI VULCAN S '15-**



**THIS KIT CONTAINS THE ITEMS PICTURED AND LABELLED BELOW.**  
**DO NOT PROCEED UNTIL YOU ARE SURE ALL PARTS ARE PRESENT.**

Please note that the way the kit is packed does not necessarily represent the way of mounting to the bike.

THE PARTS SHOWN MAY BE REPRESENTATIVE ONLY (FOR CLARITY OF INSTRUCTIONS ONLY).

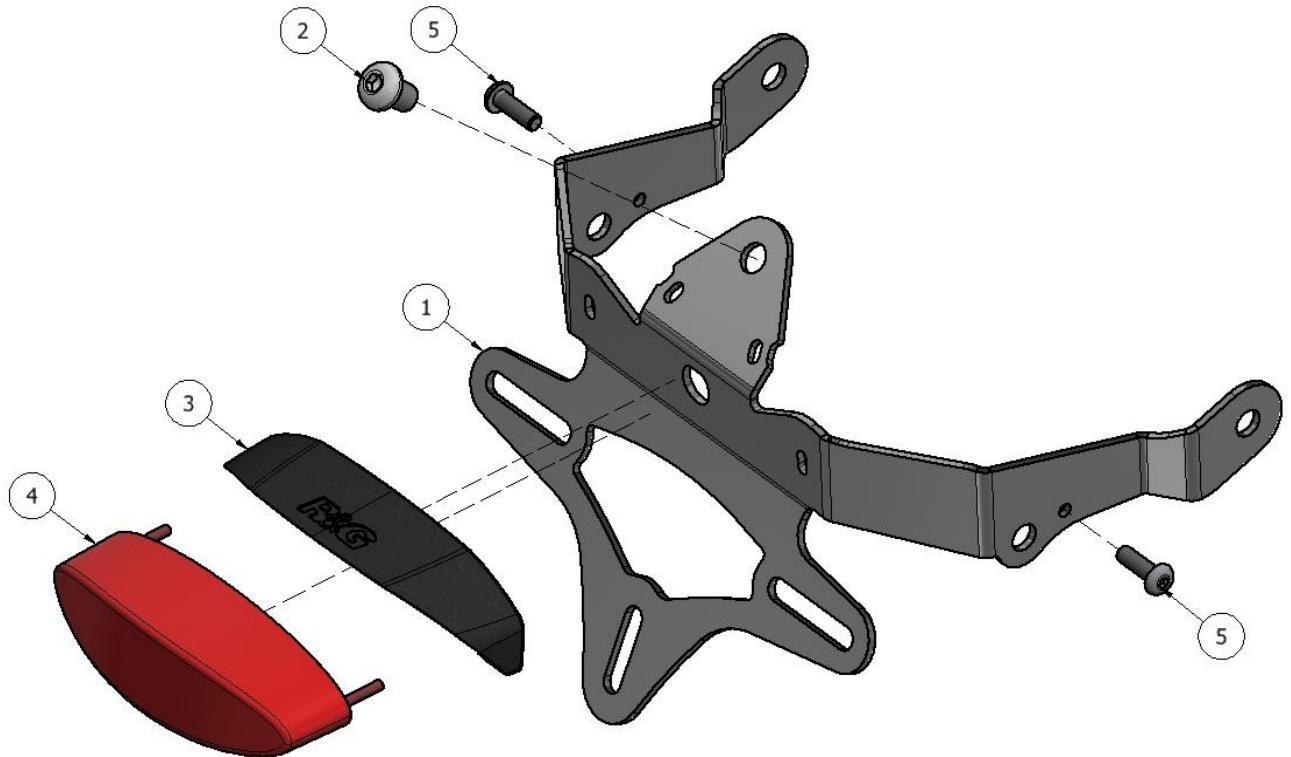

R&G

Unit 1, Shelley's Lane, East Worldham, Alton, Hampshire, GU34 3AQ  
Tel: +44 (0)1420 89007 Fax: +44 (0)1420 87301 [www.rg-racing.com](http://www.rg-racing.com) Email: [info@rg-racing.com](mailto:info@rg-racing.com)

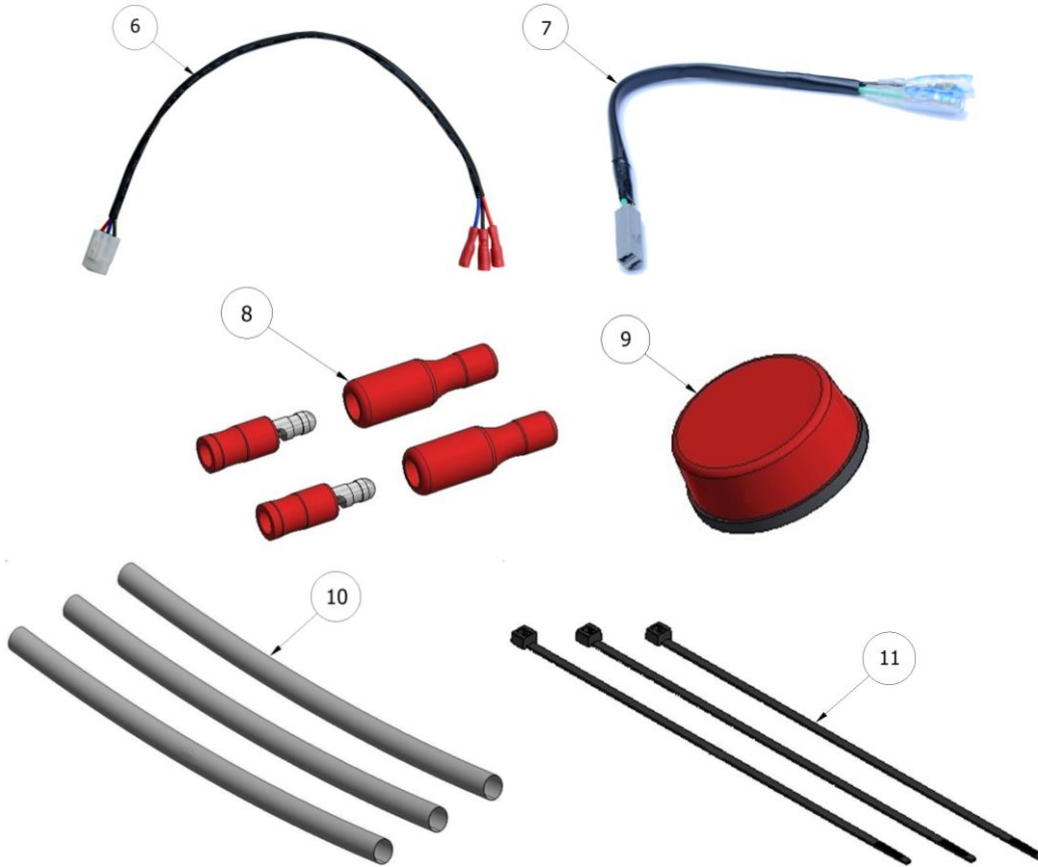

### **LEGEND**

- ITEM 1 = MAIN BRACKET (TB0186) (x1).
- ITEM 2 = M8 x 12mm LONG BUTTON HEAD BOLT (x1)
- ITEM 3 = LA0003 TAIL LIGHT SHROUD (x1).
- ITEM 4 = LA0003 TAIL LIGHT (x1).
- ITEM 5 = M5 x 16mm LONG BUTTON HEAD BOLT (x2)
- ITEM 6 = CON0037 (x1).
- ITEM 7 = CON0032 (x2).
- ITEM 8 = CON0004 (x2)
- ITEM 9 = REFLECTOR (x1).
- ITEM 10 = 150mm LENGTH OF HEATSHRINK (x3).
- ITEM 11 = 2.5mm CABLE TIES (x3).

Please note that in cases where kits are packed with rubber washers holding the components onto the bolt – *the rubber washers should be thrown away!*



### TOOLS REQUIRED

- Set of metric Allen keys to include 4, 5 & 6mm A/F size.
  - 6, 10 & 12mm spanners or sockets.
  - Phillips screwdriver.
  - Cable cutters.

### MAXIMUM TORQUE SETTINGS

- M4 Bolt = 8 Nm
- M5 Bolt = 12 Nm
- M6 Bolt = 15 Nm
- M8 Bolt = 20 Nm



Picture 1



Picture 2



Picture 3



Picture 4

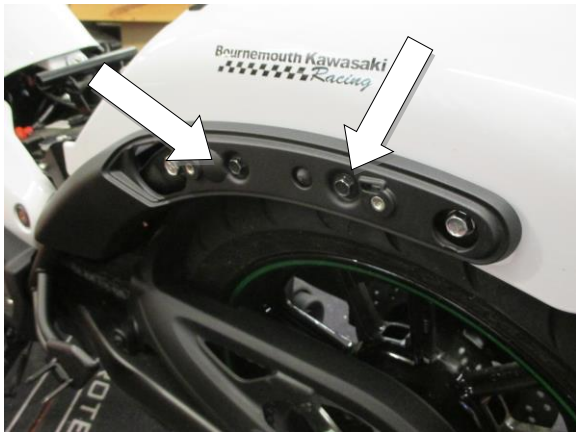

Picture 5



Picture 6



Picture 7

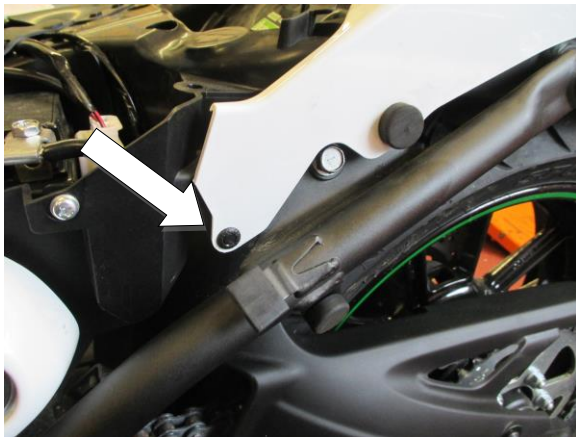

Picture 8



Picture 9



Picture 10



Picture 11



Picture 12



Picture 13



Picture 14



Picture 15



Picture 16



Picture 17



Picture 18



Picture 19



Picture 20

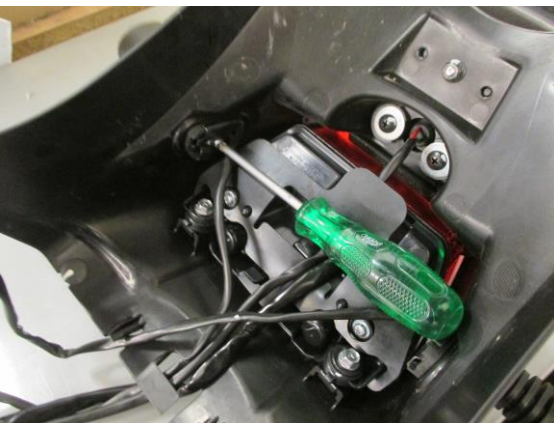

Picture 21



Picture 22



Picture 23



Picture 24



Picture 25

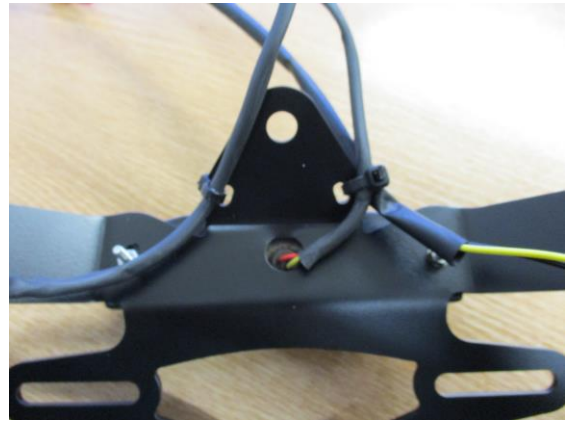

Picture 26

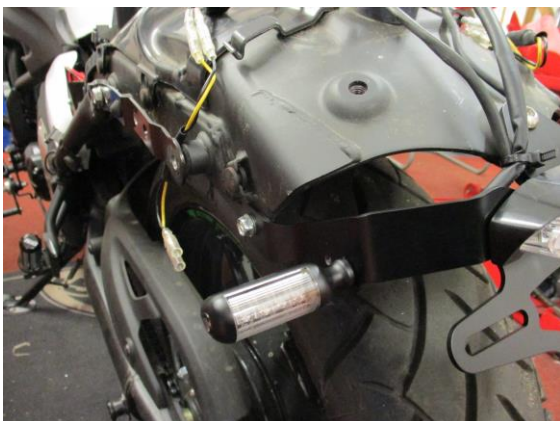

Picture 27



Picture 28

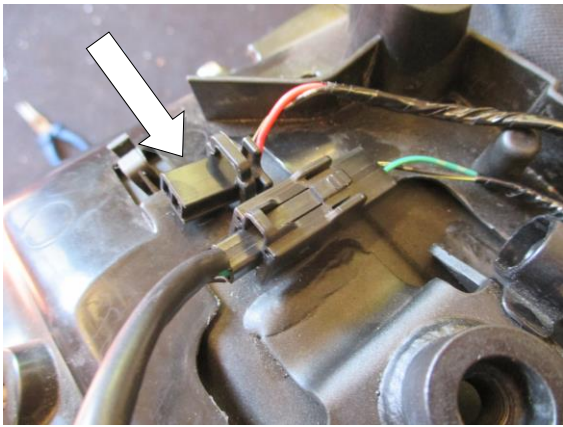

Picture 29



Picture 30



Picture 31



Picture 32



Picture 33



Picture 34





Picture 35



Picture 36

### **FITTING INSTRUCTIONS**

- To fit the R&G tail tidy, remove the pillion seat by removing the bolt as shown in picture 1.
- Remove the bolt that secures the seat in place along with the bracket for the pillion seat, as shown in picture 2.
- Remove the seat as shown in picture 3.
- Remove the two bolts that secure the plastic cover in place on both sides of the bike, as picture 4.
- With these panels off, access can be gained to the two bolts that secure the inner plastic in place, as arrowed in picture 5. Remove these two bolts, then slide the plastic panel forwards and remove from the bike. Repeat this on both sides of the bike.
- With these panels off, remove the two 12mm hex head bolts that secure the mounting plate in place and remove from the bike, as shown in picture 6. Repeat this on the other side of the bike.
- Remove the two bolts that secure the mudguard in place at the front, as arrowed in picture 7.
- At the bottom front edge of the mudguard, there is a push rivet locating the part. Remove this push rivet on both sides of the bike, as shown in picture 8.
- The plastic mudguard can now be removed from the bike, as shown in picture 9. *The rear of the mudguard will need to be spread out slightly to clear the bosses on the frame during removal.*
- Disconnect the four wiring connectors, as shown in picture 10.
- Remove the bolt securing the side of the OEM licence plate hanger on both sides of the bike, as shown in picture 11.
- Remove the two bolts on the rear of the licence plate, as shown in picture 12.
- The OEM licence plate hanger can now be removed from the bike, as shown in picture 13.
- Remove the three bolts that secure the rear metal bracket for the OEM licence plate hanger, as shown in picture 14 & 15.
- Take the licence plate bracket (item 1 – TB0186) and fit the R&G tail light and shroud (items 3 and 4) to the bracket, as shown in picture 16. Fit one length of heatshrink (item 10) to the wires and tighten the nuts on the rear, as shown in picture 17.

### **If fitting R&G Mini Indicators**

- To fit the R&G Mini Indicators, fit one length of heatshrink (item 10) to protect the indicator as shown in picture 18.
- Feed the wires through the indicator mounting hole on the tail tidy, then feed the flanged nut over the wiring and tighten onto the threaded boss of the indicator as shown in picture 19.
- Fit the indicator connectors (item 7-CON0032) as follows:

R&G

Unit 1, Shelley's Lane, East Worldham, Alton, Hampshire, GU34 3AQ

Tel: +44 (0)1420 89007 Fax: +44 (0)1420 87301 [www.rg-racing.com](http://www.rg-racing.com) Email: [info@rg-racing.com](mailto:info@rg-racing.com)



- *If fitting R&G Aero Indicators with LED's the yellow wire on the Aero Indicators connects with the green wire on item 7-CON0032 and the black wire on the Aero Indicators connects with the black/yellow wire on the item 7-CON0032. 1x set of RGR0001 resistors (available separately) are required to achieve the correct flash rate.*
- *If fitting R&G Mini Indicators with bulbs, the black wire on the Mini Indicators connects with the green wire on item 7-CON0032 and the black/white wire on the Mini Indicators connects with the black/yellow wire on item 7-CON0032.*
- *If fitting R&G Mini Indicators with LED's, the black/white wire on the Mini Indicators connects with the green wire on item 7-CON0032 and the black wire on the Mini Indicators connects with the black/yellow wire on item 7-CON0032. 1x set of RGR0001 resistors (available separately) are required to achieve the correct flash rate.*
- Repeat this procedure for both indicators and if indicators fail to illuminate, swap the connectors.

#### **If fitting OEM Indicators**

- To remove the OEM indicators, remove the Phillips screw from the rear of the indicator mount and this will allow the mounting plate to come off, as shown in picture 21.
- Remove the other metal plate that sits within the indicator rubber mount, and feed this off of the wiring. The indicator can now be twisted so that the rubber mount detaches from the plastic and can be removed from the OEM licence plate hanger, as shown in pictures 22 & 23.
- To fit the OEM indicators to the R&G Tail Tidy, remove the rubber mounting from the indicator as shown in picture 23 and thread the indicator wire through the larger hole on the side of the tail tidy.
- Using the supplied M5 bolts (item 5) secure the indicators as shown in picture 24 and 25.
- Use the cable ties supplied to neatly route the tail light and indicator wiring to the tail tidy bracket via the two slots, as shown in picture 26.
- The tail tidy assembly can now be fitted to the bike. To do this, re-use the two M6 bolts and bolt the sides of the tail tidy to the mounting holes on the motorcycle frame, as shown in picture 27.
- Take the M8 x 12mm long button head bolt (item 2) and fit it through the remaining central mounting hole on the tail tidy and tighten into the threaded hole on the motorcycle, as shown in picture 28.
- To connect the new tail light to the main loom, fit male bullet connectors (item 8) to the end of each of the 3 tail light wires. Connect the tail light to CON0037 (item 6) as follows: CON0037 (item 6) red to tail light yellow, CON0037 (item 6) blue to tail light red & CON0037 (item 6) black/yellow to tail light black.
- Connect all three connectors to the main loom on the bike and check for the correct operation of all lights at this stage (*please note that the fourth connector (arrowed in picture 29) is no longer required in use*).
- The rear mudguard can now be re-fitted to the bike using the reverse steps of how it was removed.
- Re-fit the mudguard, push rivets and two bolts as shown in pictures 30, 31 & 32.
- Re-fit the metal plates on both sides of the bike using the two bolts, as shown in picture 33.
- Re-fit the two plastic side panels using the original bolts, as shown in picture 34.
- Re-fit the two plastic cover panels using the original bolts, as shown in picture 35.
- Re-fit the seat and pillion seat using the original bolts.
- Ensure the tail tidy is securely mounted and all bolts are fully tightened.
- Re-fit the licence plate (it may require drilling).
- Depending on local laws, attach enclosed reflector in an appropriate location.
- Test the license plate illuminator and all lights before riding.

ISSUE 1 08/01/2018 (HB)

R&G

Unit 1, Shelley's Lane, East Worldham, Alton, Hampshire, GU34 3AQ  
Tel: +44 (0)1420 89007 Fax: +44 (0)1420 87301 [www.rg-racing.com](http://www.rg-racing.com) Email: [info@rg-racing.com](mailto:info@rg-racing.com)



**Digital copies of these instructions are available to download from [www.rg-racing.com](http://www.rg-racing.com)**

#### **CONSUMER NOTICE**

The catalogue description and any exhibition of samples are only broad indications of the Products and R&G may make design changes which do not diminish their performance or visual appeal and supplying them in such state shall conform to the order. The Buyer acknowledges no representation or warranty (other than as to title) has been given or will apply to the Products other than those in R&G's order or confirmation and the Buyer confirms it has chosen the Products as being of merchantable quality and suitable for its particular purposes. Where R&G fits the Products or undertakes other services it shall exercise reasonable skill and care and rectify any fault free of charge unless the workmanship has been disturbed. The Buyer is responsible for ensuring that the warranty on the motorcycle is not affected by the fitting of the Products. On return of any defective Products R&G shall at its option either supply a replacement or refund the purchase money but shall not be liable if the Products have been modified or used or maintained otherwise than in accordance with R&G's or manufacturer's instructions and good engineering practice or if the defect arises from accident or neglect. Other than identified above and subject to R&G not limiting its liability for causing death and personal injury, it shall not be liable for indirect or consequential loss and otherwise its liability shall be limited to the amounts paid by the Buyer for the Products or the fitting or service concerned. These terms do not affect the Buyer's statutory rights.

#### **R&G RETURNS POLICY (NON-FAULTY GOODS)**

Returns must be pre-authorized (if not pre-authorized the return will be rejected). Goods may only be returned direct to us if they were purchased direct from us (customer must prove if necessary). Otherwise to be returned to original vendor. Goods must be in re-sellable condition, in the opinion of R&G. All returns are subject to a 25% restocking and handling fee (25% of the gross value exc. P&P – at the prevailing price at time of purchase). The customer must pay any and all carriage charges. No returns of discontinued products, unless within 14 days of purchase. This policy does not affect your statutory rights and does not refer to faulty goods.

**R&G**

Unit 1, Shelley's Lane, East Worldham, Alton, Hampshire, GU34 3AQ

Tel: +44 (0)1420 89007 Fax: +44 (0)1420 87301 [www.rg-racing.com](http://www.rg-racing.com) Email: [info@rg-racing.com](mailto:info@rg-racing.com)



**NOTICE DE MONTAGE POUR LP0186BK SUPPORT DE PLAQUE**  
**KAWASAKI VULCAN S '15-**



**Le kit contient les articles exposés ci-dessous, vérifier que toutes les pièces soient présentes avant de procéder au montage.**  
**La façon dont le kit est emballé ne correspond pas forcément à la façon de monter les pièces sur la moto.**

**LES PARTIES PRESENTEES PEUVENT ETRE UNIQUEMENT REPRESENTATIVES  
(POUR LA CLARTE DES INSTRUCTIONS UNIQUEMENT).**

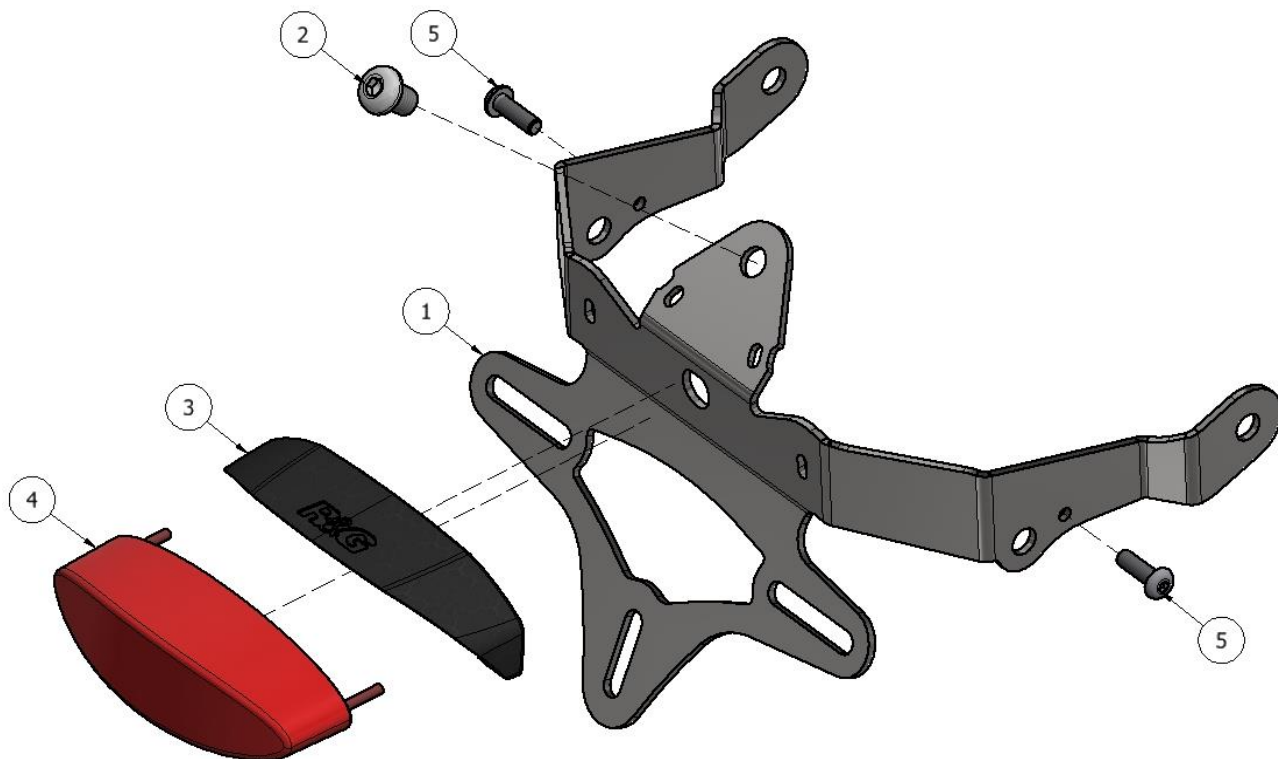

R&G

Unit 1, Shelley's Lane, East Worldham, Alton, Hampshire, GU34 3AQ  
Tel: +44 (0)1420 89007 Fax: +44 (0)1420 87301 [www.rg-racing.com](http://www.rg-racing.com) Email: [info@rg-racing.com](mailto:info@rg-racing.com)

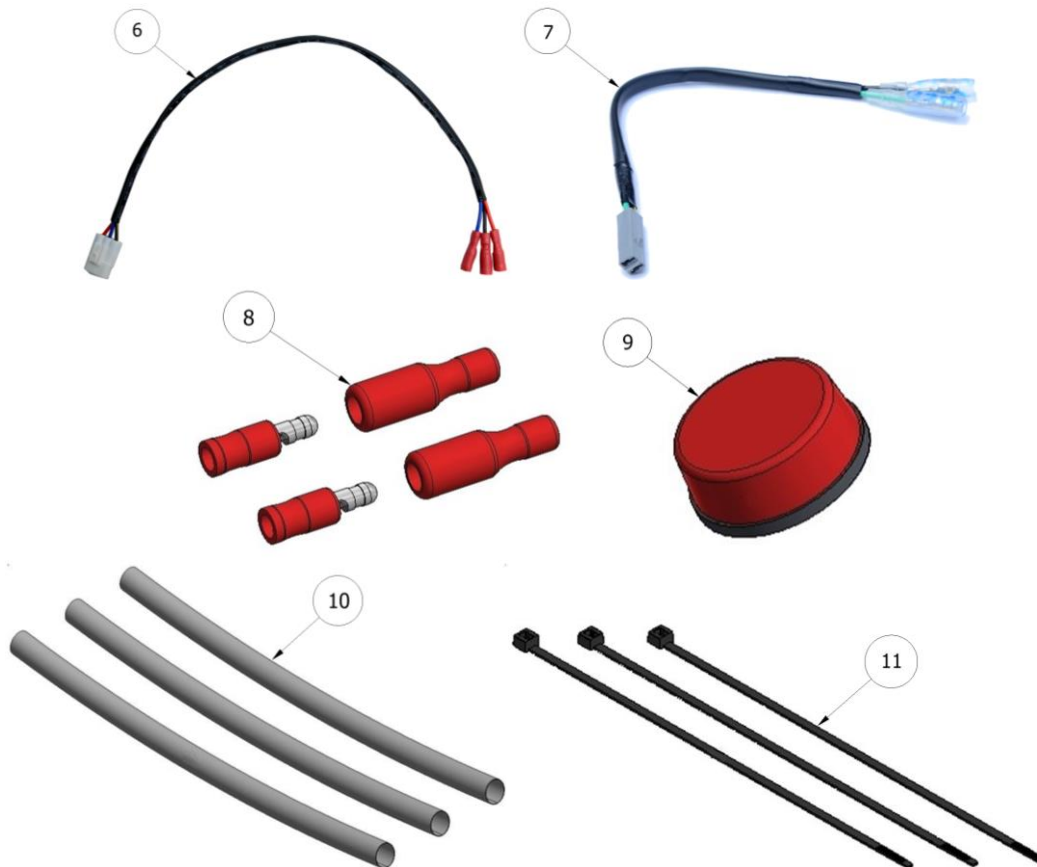

## LÉGENDE

- ARTICLE 1 = SUPPORT PRINCIPAL (TB0186) (x1).  
ARTICLE 2 = M8 x 12mm BOULON (x1)  
ARTICLE 3 = LA0003 LINCEUL (x1).  
ARTICLE 4 = LA0003 FEU DE PLAQUE (x1).  
ARTICLE 5 = M5 x 16mm BOULON (x2)  
ARTICLE 6 = CON0037 (x1).  
ARTICLE 7 = CON0032 (x2).  
ARTICLE 8 = CON0004 (x2)  
ARTICLE 9 = REFLECTEUR (x1).  
ARTICLE 10 = 150mm LONGUEUR DE MANCHON THERMORÉTRACTABLE (x3).  
ARTICLE 11 = 2.5mm COLLIERS DE SERRAGE (x3).

Notez que si les kits sont emballés avec des rondelles en caoutchouc servant à tenir les composants, *ces rondelles doivent être jetées !*



### **OUTILS REQUIS**

- Clés Allen 4, 5 & 6mm
- Clés à cliquet + douilles 6, 10 & 12mm
  - Tournevis cruciforme.
  - Coupe câble.

### **VALEURS DE SERRAGE**

- M4 BOULON = 8 Nm
- M5 BOULON = 12Nm
- M6 BOULON = 15Nm
- M8 BOULON = 20 Nm

### **NOTICE DE MONTAGE**

- Enlever le siège passager pour monter le support de plaque R&G, en enlevant le boulon, voir photo 1.
- Enlever le boulon qui fixe le siège en place avec le support de siège passager, voir photo 2.
- Enlever le siège, voir photo 3.
- Enlever les 2 boulons qui fixent le cache plastique en place des 2 côtés de la moto, voir photo 4.
- Une fois les panneaux enlevés, l'accès est possible aux 2 boulons qui fixent le plastique interne en place, voir photo 5. Enlever ces 2 boulons, puis glisser le panneau plastique vers l'avant avant de l'enlever de la moto. Répéter cela des 2 côtés de la moto.
- Une fois les panneaux enlevés, enlever les 2 boulons 12mm qui fixent la plaque de fixation en place puis enlevez la de la moto, voir photo 6. Répéter cette operation de l'autre côté de la moto.
- Enlever les 2 boulons qui fixent le garde-boue en place à l'avant, voir photo 7.
- Sur le bord avant inférieur du garde-boue, il y a un rivet qui fixe la partie. Enlever ce rivet des 2 côtés de la moto, voir photo 8.
- Le garde-boue en plastique peut maintenant être enlevé de la moto, voir photo 9. L'arrière du garde-boue devra être légèrement écarté pour apercevoir les trous dans le cadre, lors du démontage.
- Déconnecter les 4 connecteurs de fils, voir photo 10.
- Enlever le boulon qui fixe le côté du support de plaque d'origine des 2 côté de la moto, voir photo 11.
- Enlever les 2 boulons à l'arrière de la plaque d'immatriculation, voir photo 12.
- Le support de plaque d'origine peut maintenant être enlevés de la moto, voir photo 13.
- Enlever les 3 boulons qui fixent le support arrière en métal du support de plaque d'origine, voir photo 14 & 15.
- Prendre le support de plaque (article 1 – TB0186) et monter le feu de plaque R&G et le linceul (articles 3 and 4) sur le support, voir photo 16. Monter une longueur de manchon thermo rétractable (article 10) sur les fils puis serrer les écrous à l'arrière, voir photo 17.

### **Si vous montez les mini clignotants R&G**

- Pour monter les mini clignotants R&G, appliquez une longueur de manchon thermo rétractable (article 10) pour protéger le fil de clignotant, voir photo 18.
- Passer les fils dans le trou de fixation de clignotant sur le support de plaque, puis passer l'écrou sur le fil avant de serrer sur le trou fileté du clignotant, voir photo 19.
- Monter les connecteurs de clignotant (article 7-CON0032) comme suit :
- *Si vous montez les clignotants latéraux R&G à LED, le fil jaune des clignotants latéraux se connecte avec le fil vert sur l'article 7-CON0032 et le fil noir sur les clignotants latéraux se connecte avec le fil noir/jaune sur l'article 7-CON0032. 1x set de résistances RGR000 (disponible séparément) sont nécessaire pour obtenir le bon niveau d'éclairage.*

R&G

Unit 1, Shelley's Lane, East Worldham, Alton, Hampshire, GU34 3AQ

Tel: +44 (0)1420 89007 Fax: +44 (0)1420 87301 [www.rg-racing.com](http://www.rg-racing.com) Email: [info@rg-racing.com](mailto:info@rg-racing.com)



- Si vous montez les mini clignotants R&G à ampoule, le fil noir des mini clignotants se connecte avec le fil vert sur l'article 7-CON0032 et le fil noir/blanc sur le mini clignotants se connecte avec le fil noir/jaune sur l'article 7-CON0032.
- Si vous montez les mini clignotants R&G à LED, le fil noir/blanc sur le mini clignotants se connecte avec le fil vert sur l'article 7-CON0032 et le fil noir sur les mini clignotants se connecte avec le fil noir/jaune sur l'article 7-CON0032. 1x set de résistances RGR0001 (disponible séparément) sont nécessaire pour obtenir le bon niveau d'éclairage
- Répéter cette action pour les 2 clignotants et si les clignotants ne s'allument pas, tournez les connecteurs.

### **Si vous montez les clignotants d'origine**

- Pour enlever les clignotants d'origine, enlever la vis à l'arrière du support clignotant, et cela permettra à la plaque de fixation de s'enlever, voir photo 21.
- Enlever l'autre plaque en métal qui se trouve sur le support clignotant en caoutchouc, puis passer le fil à travers. Le clignotant peut à présent être enroulé de façon à ce que le support en caoutchouc se détache du plastique et puisse être enlevé du support de plaque d'origine, voir photos 22 & 23.
- Pour monter les clignotants d'origine sur le support de plaque R&G, enlever le support de fixation en caoutchouc du clignotant, voir photo 23 et passer le fil de clignotant à travers le trou large sur le côté du support de plaque.
- En utilisant les boulons M5 fournis (article 5) fixer les clignotants, voir photo 24 et 25.
- Utiliser les colliers de serrage fournis pour router le feu de plaque et le fil de clignotant sur le support de plaque via les 2 fentes, voir photo 26.
- L'ensemble du support de plaque peut à présent être monté sur la moto. Pour cela, réutiliser les 2 boulons M6 et boulonner les bords du support de plaque dans les trous de fixation du cadre de la moto, voir photo 27.
- Prendre le boulon M8 x 12mm (article 2) et insérer le dans le trou de fixation central principal sur le support de plaque puis serrer dans le trou fileté de la moto, voir photo 28.
- Pour connecter le nouveau feu de plaque sur le faisceau principal, monter les connecteurs mâles, (article 8) sur l'extrémité de chacun des 3 fils de feux de plaque. Connecter le feu de plaque au CON0037 (article 6) comme suit : CON0037 (article 6) rouge au feu de plaque jaune, CON0037 (article 6) bleu au feu de plaque rouge & CON0037 (article 6) noir/jaune au feu de plaque noir.
- Connecter les 3 connecteurs au faisceau principal sur la moto puis vérifier que l'ensemble des feux fonctionnent à ce stade du montage (*Notez que le 4e connecteur indiqué sur la photo 29) n'est plus nécessaire*).
- Le garde-boue arrière peut maintenant être monté sur la moto en procédant à l'inverse de la façon dont il a été démonté.
- Remonter le garde-boue, les rivets et les 2 boulons indiqués sur les photos 30, 31 & 32.
- Remonter les plaques en métal des 2 côtés de la moto en utilisant les 2 boulons, voir photo 33.
- Remonter les 2 panneaux en plastique en utilisant les boulons d'origine, voir photo 34.
- Remonter les 2 panneaux en plastique en utilisant les boulons d'origine, voir photo 35.
- Remonter le siège pilote et le siège passager en utilisant les boulons d'origine.
- Veiller à ce que le support de plaque soit correctement monté et que tous les boulons soient correctement serrés.
- Remonter la plaque d'immatriculation (peut nécessiter un perçage).
- Selon la loi locale, positionner les réflecteurs aux endroits appropriés.
- Tester les clignotants et le feu de plaque pour vérifier le fonctionnement et le niveau.

ISSUE 1 08/01/2018 (HB)

R&G

Unit 1, Shelley's Lane, East Worldham, Alton, Hampshire, GU34 3AQ  
Tel: +44 (0)1420 89007 Fax: +44 (0)1420 87301 [www.rg-racing.com](http://www.rg-racing.com) Email: [info@rg-racing.com](mailto:info@rg-racing.com)



**Notice disponible au téléchargement sur [www.rg-racing.com](http://www.rg-racing.com)**

#### **CONSUMER NOTICE**

The catalogue description and any exhibition of samples are only broad indications of the Products and R&G may make design changes which do not diminish their performance or visual appeal and supplying them in such state shall conform to the order. The Buyer acknowledges no representation or warranty (other than as to title) has been given or will apply to the Products other than those in R&G's order or confirmation and the Buyer confirms it has chosen the Products as being of merchantable quality and suitable for its particular purposes. Where R&G fits the Products or undertakes other services it shall exercise reasonable skill and care and rectify any fault free of charge unless the workmanship has been disturbed. The Buyer is responsible for ensuring that the warranty on the motorcycle is not affected by the fitting of the Products. On return of any defective Products R&G shall at its option either supply a replacement or refund the purchase money but shall not be liable if the Products have been modified or used or maintained otherwise than in accordance with R&G's or manufacturer's instructions and good engineering practice or if the defect arises from accident or neglect. Other than identified above and subject to R&G not limiting its liability for causing death and personal injury, it shall not be liable for indirect or consequential loss and otherwise its liability shall be limited to the amounts paid by the Buyer for the Products or the fitting or service concerned. These terms do not affect the Buyer's statutory rights.

#### **R&G RETURNS POLICY (NON-FAULTY GOODS)**

Returns must be pre-authorized (if not pre-authorized the return will be rejected). Goods may only be returned direct to us if they were purchased direct from us (customer must prove if necessary). Otherwise to be returned to original vendor. Goods must be in re-sellable condition, in the opinion of R&G. All returns are subject to a 25% restocking and handling fee (25% of the gross value exc. P&P – at the prevailing price at time of purchase). The customer must pay any and all carriage charges. No returns of discontinued products, unless within 14 days of purchase. This policy does not affect your statutory rights and does not refer to faulty goods.

**R&G**

Unit 1, Shelley's Lane, East Worldham, Alton, Hampshire, GU34 3AQ

Tel: +44 (0)1420 89007 Fax: +44 (0)1420 87301 [www.rg-racing.com](http://www.rg-racing.com) Email: [info@rg-racing.com](mailto:info@rg-racing.com)





**MONTAGEANLEITUNG FÜR LP0186BK KENNZEICHENHALTER**  
**KAWASAKI VULCAN S '15-**



**ALLE KIT-TEILE SIND UNTEN ABGEBILDET UND GEKENNZEICHNET. BEVOR SIE MIT DER MONTAGE BEGINNEN, ÜBERPRÜFEN SIE, DASS ALLE TEILE VORHANDEN SIND.**

**Hinweis: Die Verpackung der Teile stellt nicht die Reihenfolge der Montage dar.**

DIE UNTEN ABGEBILDETEN TEILE DIENEN LEDIGLICH ZUR ERKLÄRUNG

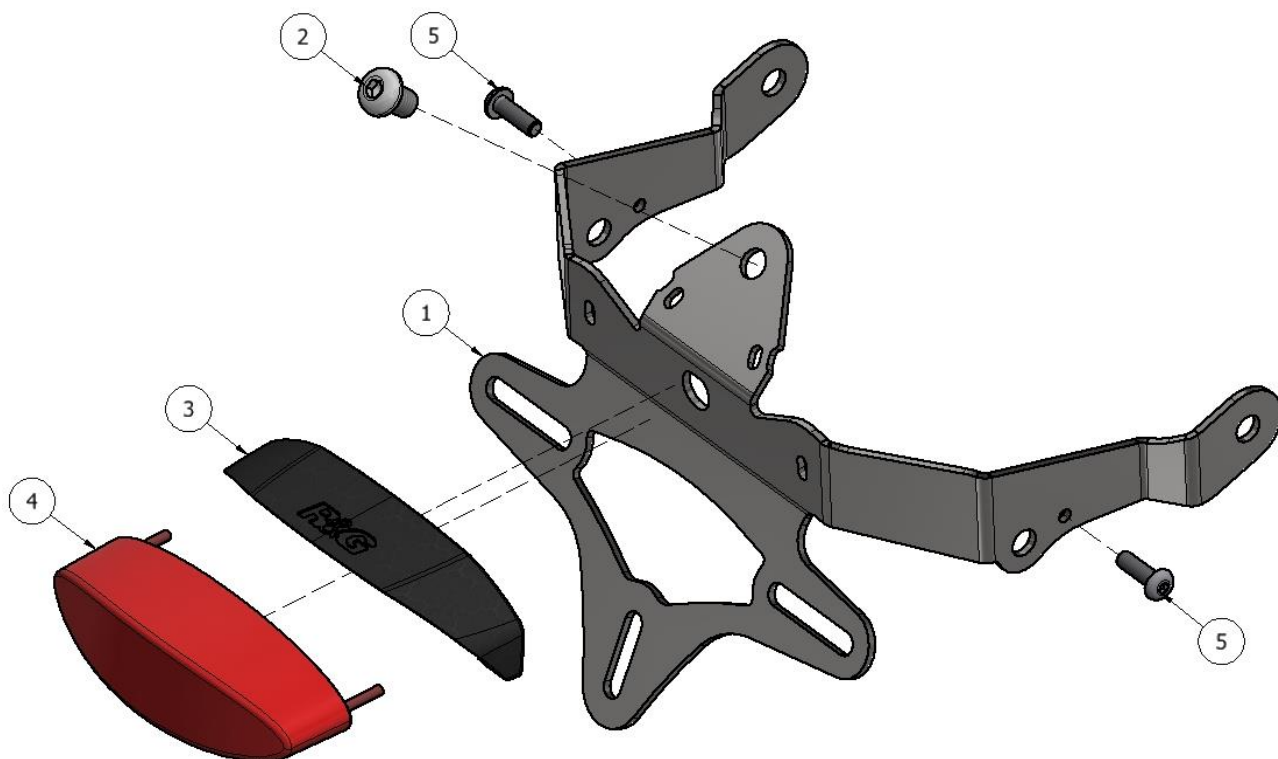

R&G

Unit 1, Shelley's Lane, East Worldham, Alton, Hampshire, GU34 3AQ  
Tel: +44 (0)1420 89007 Fax: +44 (0)1420 87301 [www.rg-racing.com](http://www.rg-racing.com) Email: [info@rg-racing.com](mailto:info@rg-racing.com)

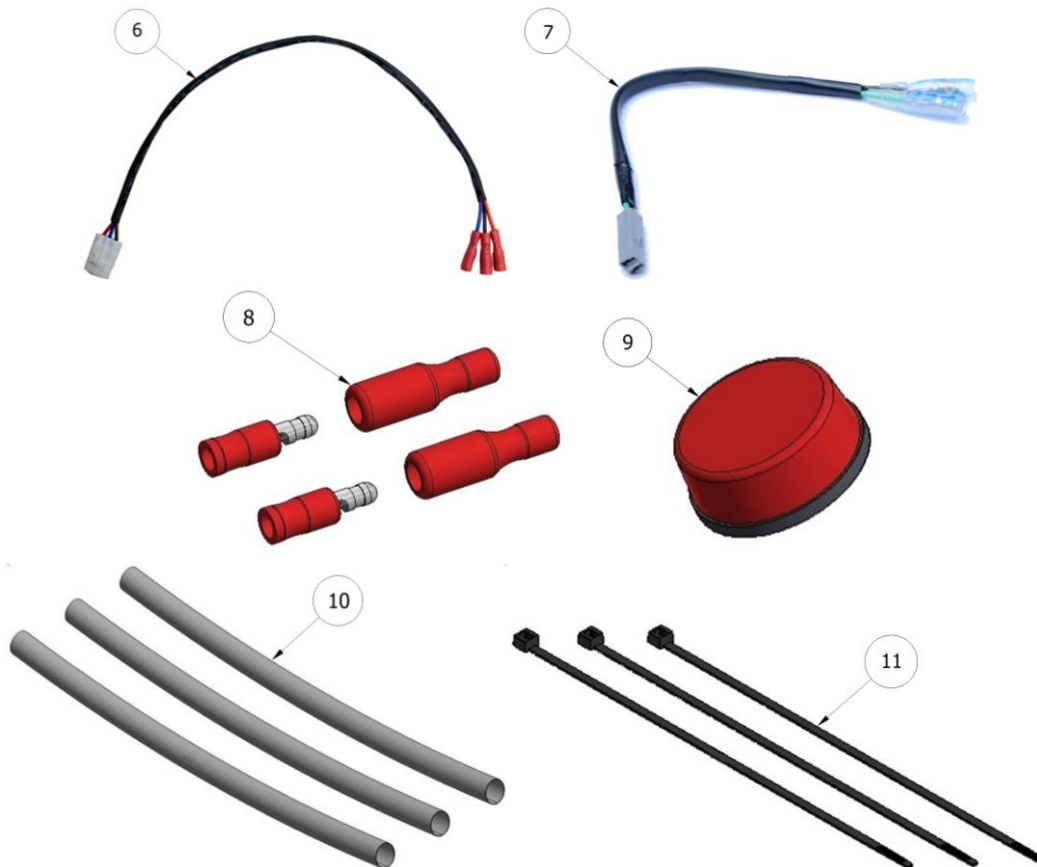

### **LIEFERUMFANG**

- ARTIKEL 1 = KENNZEICHENHALTER (TB0186) (x1)
- ARTIKEL 2 = M8 x 12mm INBUSSCHRAUBE (x1)
- ARTIKEL 3 = LA0003 ABDECKUNG FÜR DIE KENNZEICHENBELEUCHTUNG (x1)
- ARTIKEL 4 = LA0003 KENNZEICHENBELEUCHTUNG (x1)
- ARTIKEL 5 = M5 x 15mm INBUSSCHRAUBE (x1)
- ARTIKEL 6 = CON0037 (x1)
- ARTIKEL 7 = CON0032 (x2)
- ARTIKEL 8 = CON0004 (x2)
- ARTIKEL 9 = RÜCKSTRAHLER (x1)
- ARTIKEL 10 = 150mm SCHRUMPFSCHLAUCH (x3)
- ARTIKEL 11 = 2.5mm KABELBINDER (x3)

Hinweis für Kits mit Plastikunterlegscheiben an den Schrauben – *Diese Plastikunterlegscheiben werden nicht für den Einbau benötigt!*



### **SIE BENÖTIGEN FOLGENDES WERKZEUG**

- Satz Inbusschlüssel mit 4, 5 & 6mm A/F Inbusschlüssel
  - 6, 10 & 12mm Schraubenschlüssel
  - Kreuzschlitzschraubendreher
    - Seitenschneider

### **MAXIMALE ANZUGSDREHMOMENTE:**

M4 SCHRAUBE = 8Nm

M5 SCHRAUBE = 12Nm

M6 SCHRAUBE = 15Nm

M8 SCHRAUBE = 20Nm

### **MONTAGEANLEITUNG**

- Um den R&G Kennzeichenhalter montieren zu können, entfernen Sie zuerst den Soziussitz (entfernen Sie die Schraube – siehe Abbildung 1).
- Entfernen Sie die Schraube, die den Sitz befestigt zusammen mit der Halterung für den Soziussitz – siehe Abbildung 2.
- Entfernen Sie den Sitz wie in Abbildung 3 abgebildet.
- Entfernen Sie die zwei Schrauben, die die Plastikabdeckung in Position halten an beiden Seiten des Motorrades (siehe Abbildung 4).
- Sobald diese Teile abmontiert sind, ist der Zugang zu den zwei Schrauben, die die innere Kunststoffteile befestigen möglich (siehe Abbildung 5). Entfernen Sie die zwei Schrauben. Danach das Kunststoffteil nach vorne schieben und vom Motorrad entfernen. Diesen Schritt an beiden Seiten des Motorrades ausführen.
- Entfernen Sie die zwei 12mm Sechskantschrauben, die die Montageplatte befestigen, dann entfernen Sie die Montageplatte vom Motorrad – siehe Abbildung 6. Diesen Schritt an der anderen Seite des Motorrades wiederholen.
- Entfernen Sie die zwei Schrauben, die den Kotflügel vorne befestigen – siehe Abbildung 7.
- An der unteren Kante des Kotflügels ist eine Niete, die das Teil fixiert. Entfernen Sie die Niete an beiden Seiten des Motorrades – siehe Abbildung 8.
- Der Kotflügel aus Kunststoff kann nun vom Motorrad entfernt werden - siehe Abbildung 9. *Das hintere Teil des Kotflügels muss beim Abmontieren etwas ausgebreitet werden, sodass die Naben nicht dabei berührt werden.*
- Trennen Sie die vier Steckverbinder, wie in Abbildung 10 abgebildet.
- Entfernen Sie die Schrauben, die die Seiten des original Kennzeichenhalters an beiden Seiten des Motorrades befestigen – siehe Abbildung 11.
- Entfernen Sie die zwei Schrauben hinten am Kennzeichenhalter – siehe Abbildung 12.
- Der original Kennzeichenhalter kann nun vom Motorrad entfernt werden – siehe Abbildung 13.
- Entfernen Sie die drei Schrauben, die die hintere Metallhalterung für den original Kennzeichenhalter befestigen – siehe Abbildungen 14 & 15.
- Montieren Sie die R&G Kennzeichenbeleuchtung und Abdeckung (Artikel 3 und 4) am Kennzeichenhalter (Artikel 2 – TB0186) wie in Abbildung 16 abgebildet. 1 x Strumpfschlauch (Artikel 10) an den Kabeln anbringen und die Muttern hinten befestigen, wie in Abbildung 17 abgebildet.

#### **Wenn Sie Miniblinker verwenden**

- Um die R&G Mini-Blinker montieren zu können, zuerst jeweils 1 x Schrumpfschlauch (Artikel 10) an den Blinkerkabeln anbringen – siehe Abbildung 18.

R&G

Unit 1, Shelley's Lane, East Worldham, Alton, Hampshire, GU34 3AQ

Tel: +44 (0)1420 89007 Fax: +44 (0)1420 87301 [www.rg-racing.com](http://www.rg-racing.com) Email: [info@rg-racing.com](mailto:info@rg-racing.com)



- Führen Sie die Kabel durch die Montageöffnung für die Blinker am Kennzeichenhalter. Die Flanshmutter über die Kabel zum Gewindeeinsatz für den Blinker schieben und befestigen – siehe Abbildung 19.
- Montieren Sie die Kabelverbinder für die Blinker (Artikel 7-CON0032) wie folgt:
- *Wenn Sie die R&G Aero Blinker mit LEDs montieren, das gelbe Kabel des Aero-Blinkers mit dem grünen Kabel des Artikels 7 (CON0032) verbinden und das schwarze Kabel des Aero-Blinkers mit dem schwarz/gelben Kabel des Artikels 7 (CON0032). 1x Satz RGR0001 Widerstände (separat erhältlich) wird benötigt, um die richtige Blitzgeschwindigkeit einzustellen.*
- *Wenn Sie R&G Miniblinker mit Glühbirnen montieren, das schwarz Kabel des Miniblinkers mit dem grünen Kabel des Artikels 7- CON0032 verbinden und das schwarze Kabel des Miniblinkers mit dem schwarz/gelben Kabel des Artikels 7 - CON0032.*
- *Wenn Sie R&G Miniblinker mit LEDs montieren, das schwarz/weiße Kabel des Miniblinkers mit grünen Kabel des Artikels 7-CON0032 verbinden und das schwarze Kabel des Miniblinkers mit dem grünen Kabel der original Verkabelung verbinden. 1x Satz RGR0001 Widerstände (separat erhältlich) wird benötigt, um die richtige Blitzgeschwindigkeit einzustellen*
- Wiederholen Sie den Vorgang mit dem zweiten Blinker. Wenn die Beleuchtung nicht funktionieren sollte, tauschen Sie die Kabelverbinder untereinander.

#### **Wenn Sie die original Blinker montieren**

- Um die original Blinker zu entfernen, entfernen Sie die Kreuzschlitzschraube hinten an der Blinkerhalterung. Somit kann die Montageplatte sich lösen – siehe Abbildung 21.
- Entfernen Sie die andere Metallplatte, die innerhalb der Gummihalterung für den Blinker platziert ist, und entfernen Sie sie vom Kabel. Der Blinker kann nun gedreht werden, sodass die Gummihalterung sich vom Kunststoff abtrennt und vom original Kennzeichenhalter entfernt werden kann – siehe Abbildungen 22 & 23.
- Um die original Blinker am R&G Kennzeichenhalter zu montieren, entfernen Sie die Gummihalterung vom Blinker – siehe Abbildung 23 und führen Sie das Blinkerkabel durch die große Öffnung an der Seite des Kennzeichenhalters.
- Benutzen Sie die M5 Schrauben vom Kit (Artikel 5), um die Blinker zu befestigen – siehe Abbildungen 24 und 25.
- Benutzen Sie die mitgelieferten Kabelbinder, um die Kabel für die Kennzeichenbeleuchtung und Blinker ordentlich an den zwei Spalten zu befestigen – siehe Abbildung 26.
- Der Kennzeichenhalter kann nun am Motorrad montiert werden. Verwenden Sie die zwei M6 Schrauben wieder, um den Kennzeichenhalter an den Befestigungsbohrungen an beiden Seiten des Rahmens zu befestigen – siehe Abbildung 27.
- Führen Sie die M8 x 12mm Inbusschraube (Artikel 2) durch die übrige Befestigungsbohrung am Kennzeichenhalter in die Gewindebohrung am Motorrad ein und ziehen Sie sie fest – siehe Abbildung 28.
- Um die neue Kennzeichenbeleuchtung am Kabelbaum anzuschließen, montieren Sie die männlichen Kabelverbinder (Artikel 8) an den Enden der drei Kabel. Verbinden Sie die Kennzeichenbeleuchtung mit CON0037 (Artikel 6) wie folgt: CON0037 (Artikel 6) rot zu Kennzeichenbeleuchtung gelb, CON0037 (Artikel 6) blau zu Kennzeichenbeleuchtung rot & CON0037 (Artikel 6) schwarz/gelb zu Kennzeichenbeleuchtung schwarz.
- Verbinden Sie die alle drei Steckverbinder am Kabelbaum wieder und überprüfen Sie, dass die Beleuchtung ordnungsgemäß funktioniert (*Hinweis: der vierte Steckverbinder, der in Abbildung 29 gekennzeichnet ist, wird nicht mehr benutzt*).
- Das hintere Schutzblech kann nun wieder montiert werden (einfach die Schritte für die Entfernung in umgekehrter Reihenfolge ausführen).
- Montieren Sie das Schutzblech, die Plastiknieten und die zwei Schrauben wieder - siehe Abbildungen 30, 31, & 32.

R&G

Unit 1, Shelley's Lane, East Worldham, Alton, Hampshire, GU34 3AQ

Tel: +44 (0)1420 89007 Fax: +44 (0)1420 87301 [www.rg-racing.com](http://www.rg-racing.com) Email: [info@rg-racing.com](mailto:info@rg-racing.com)



- Montieren und befestigen Sie die Metalplatten an beiden Seiten des Motorrads – verwenden Sie die zwei Schrauben, wie in Abbildung 33 abgebildet.
- Montieren Sie die zwei Plastikhalterungen an beiden Seiten des Motorrads wieder – verwenden Sie hierbei die Originalschrauben – siehe Abbildung 34.
- Montieren Sie die zwei Abdeckungen an beiden Seiten des Motorrads wieder – verwenden Sie hierbei die Originalschrauben – siehe Abbildung 35.
- Montieren Sie den Sitz und Beifahrersitz wieder mit den original Schrauben.
- Überprüfen Sie, dass der Kennzeichenhalter sicher montiert ist und alle Schrauben festgezogen sind.
- Montieren Sie das amtliche Kennzeichen (Bohrungen im Kennzeichen evtl. notwendig).
- Entsprechend der gesetzlichen Vorschriften, den mitgelieferten Rückstrahler anbringen.
- Überprüfen Sie die Funktion der Beleuchtung (Blinker und Kennzeichenhalter-Beleuchtung) vor Gebrauch des Fahrzeuges.

AUSGABE 2 08/01/2018 (HB)

**Eine digitale Version dieser Montageanleitung kann auf folgender Seite heruntergeladen werden:**

[www.rg-racing.com](http://www.rg-racing.com)

#### CONSUMER NOTICE

The catalogue description and any exhibition of samples are only broad indications of the Products and R&G may make design changes which do not diminish their performance or visual appeal and supplying them in such state shall conform to the order. The Buyer acknowledges no representation or warranty (other than as to title) has been given or will apply to the Products other than those in R&G's order or confirmation and the Buyer confirms it has chosen the Products as being of merchantable quality and suitable for its particular purposes. Where R&G fits the Products or undertakes other services it shall exercise reasonable skill and care and rectify any fault free of charge unless the workmanship has been disturbed. The Buyer is responsible for ensuring that the warranty on the motorcycle is not affected by the fitting of the Products. On return of any defective Products R&G shall at its option either supply a replacement or refund the purchase money but shall not be liable if the Products have been modified or used or maintained otherwise than in accordance with R&G's or manufacturer's instructions and good engineering practice or if the defect arises from accident or neglect. Other than identified above and subject to R&G not limiting its liability for causing death and personal injury, it shall not be liable for indirect or consequential loss and otherwise its liability shall be limited to the amounts paid by the Buyer for the Products or the fitting or service concerned. These terms do not affect the Buyer's statutory rights.

#### R&G RETURNS POLICY (NON-FAULTY GOODS)

Returns must be pre-authorized (if not pre-authorized the return will be rejected). Goods may only be returned direct to us if they were purchased direct from us (customer must prove if necessary). Otherwise to be returned to original vendor. Goods must be in re-sellable condition, in the opinion of R&G. All returns are subject to a 25% restocking and handling fee (25% of the gross value exc. P&P – at the prevailing price at time of purchase). The customer must pay any and all carriage charges. No returns of discontinued products, unless within 14 days of purchase. This policy does not affect your statutory rights and does not refer to faulty goods.

R&G

Unit 1, Shelley's Lane, East Worldham, Alton, Hampshire, GU34 3AQ

Tel: +44 (0)1420 89007 Fax: +44 (0)1420 87301 [www.rg-racing.com](http://www.rg-racing.com) Email: [info@rg-racing.com](mailto:info@rg-racing.com)